

ANTHONY JAMES PARTNERS.com

OWNER'S REPRESENTATIVE | AV CONSULTANT

STOCKTON ARENA RFP RENDERINGS

08.26.22

This artwork is protected under federal and international copyright law. Express permission from Anthony James Partners (AJP) is required for reproduction. Renderings are for the exclusive use of designated clients, associates and AJP. These renderings do not represent fabrication or structural engineer-certified or stamped documents. Monitor and/or printer calibration may impair visual accuracy of specified colors.

EXISTING CONDITIONS

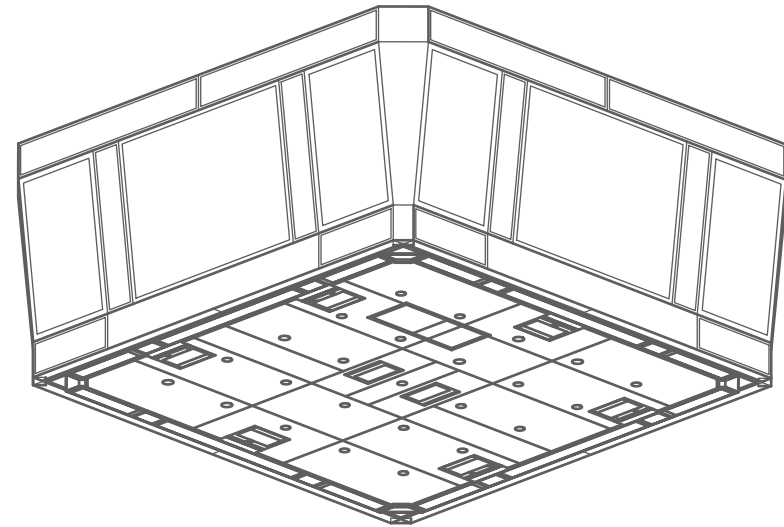

CENTER HUNG UPGRADES

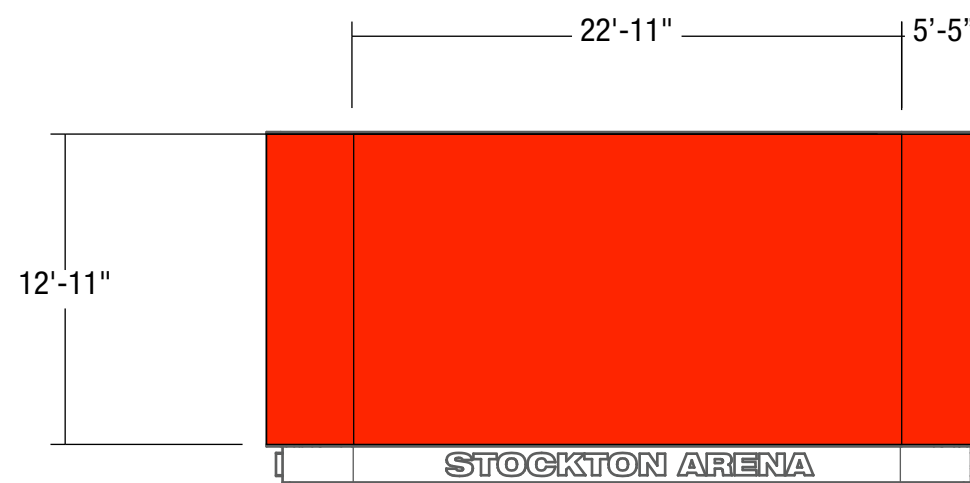
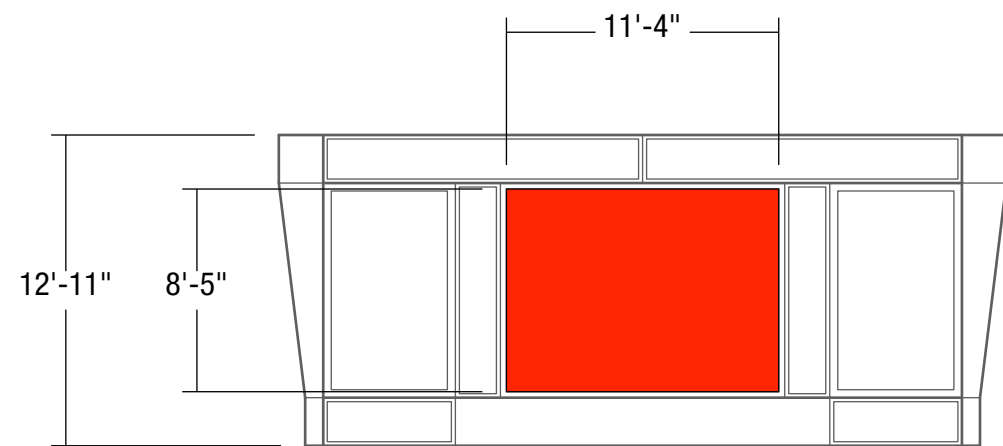
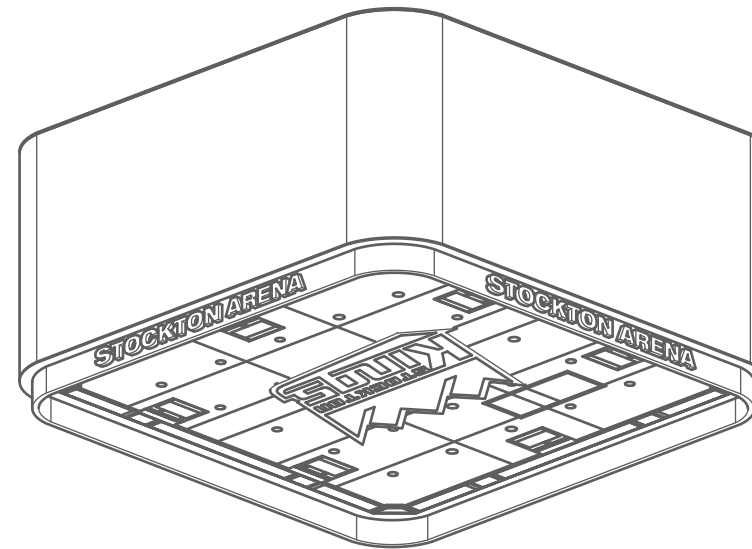

CENTER HUNG COMPARISON TO EXISTING CONDITIONS



CENTER HUNG INSET RENDER

**ANTHONY
JAMES
PARTNERS**

3900 WESTERRE PARKWAY, SUITE 300 RICHMOND, VIRGINIA 23233
804.727.0070
www.anthonijamespartners.com

THIS ARTWORK IS PROTECTED UNDER FEDERAL AND INTERNATIONAL COPYRIGHT LAW. EXPRESS PERMISSION FROM ANTHONY JAMES PARTNERS (AJP) IS REQUIRED FOR REPRODUCTION. RENDERINGS ARE FOR THE EXCLUSIVE USE OF DESIGNATED CLIENTS, ASSOCIATES AND AJP. THESE RENDERINGS DO NOT REPRESENT FABRICATION OR STRUCTURAL ENGINEER CERTIFIED OR STAMPED DOCUMENTS. MONITOR AND/OR PRINTER CALIBRATION MAY IMPAIR VISUAL ACCURACY OF SPECIFIED COLORS.

STOCKTON ARENA

RFP RENDERINGS

CONTINUOUS PRIMARY
LED VIDEO DISPLAY

ARENA NAMING RIGHTS
SIGNAGE

NAMING RIGHTS RING

UNDERBELLY TENSION
FABRIC ACROSS
BOTTOM OF CH



CENTER HUNG RENDER

**ANTHONY
JAMES
PARTNERS**

3900 WESTERRE PARKWAY, SUITE 300
RICHMOND, VIRGINIA 23233

804.727.0070
www.anthonyjamespartners.com

THIS ARTWORK IS PROTECTED UNDER FEDERAL AND INTERNATIONAL COPYRIGHT LAW. EXPRESS PERMISSION FROM ANTHONY JAMES PARTNERS (AJP) IS REQUIRED FOR REPRODUCTION. RENDERINGS ARE FOR THE EXCLUSIVE USE OF DESIGNATED CLIENTS, ASSOCIATES AND AJP. THESE RENDERINGS DO NOT REPRESENT FABRICATION OR STRUCTURAL ENGINEER CERTIFIED OR STAMPED DOCUMENTS. MONITOR AND/OR PRINTER CALIBRATION MAY IMPAIR VISUAL ACCURACY OF SPECIFIED COLORS.

STOCKTON ARENA

RFP RENDERINGS

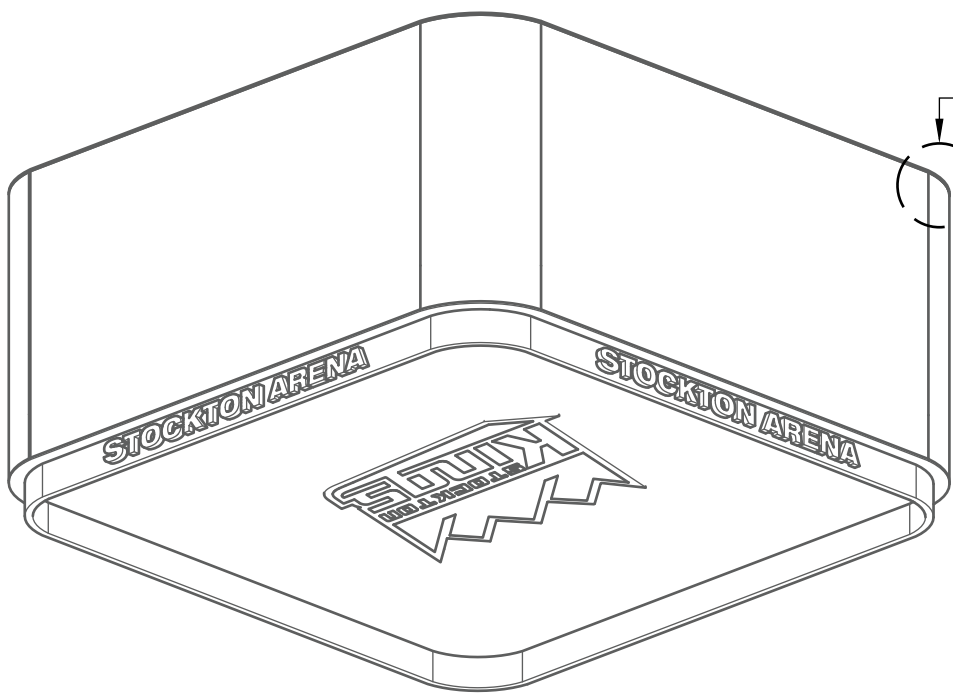
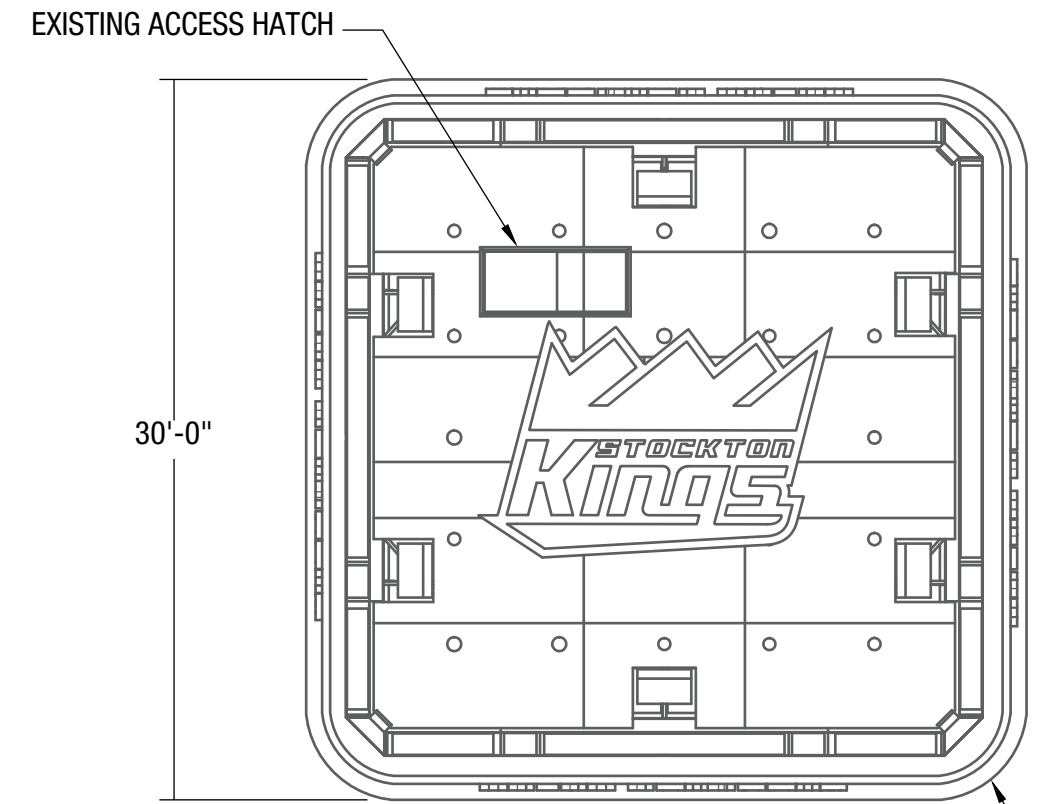
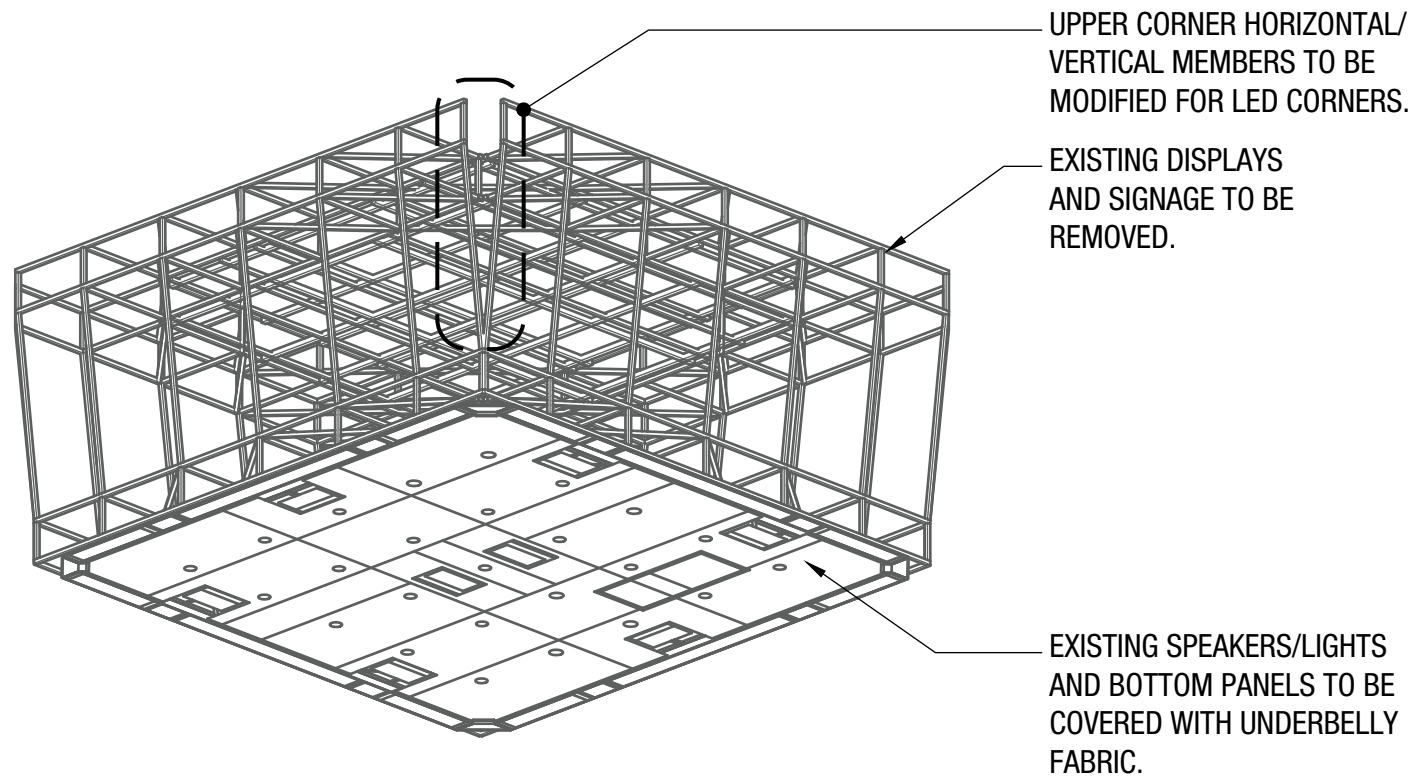

DETAIL

1" PERIMETER .090 ALUM.
PAINT SEMI-GLOSS BLACK.

LED MODULES

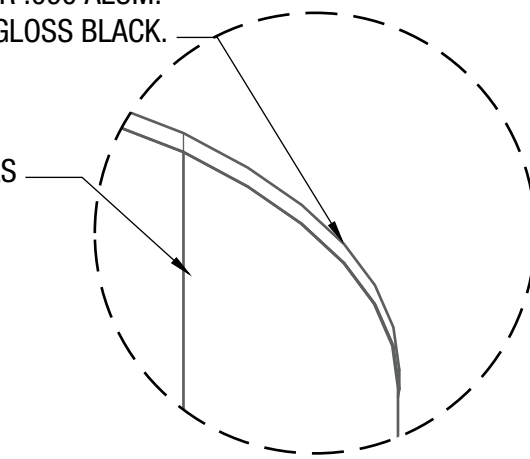

DETAIL OF BOTTOM/TOP OF LED FACES
NTS

REVERSE PLAN
1/8" = 1'-0"

CORNER LED
R.3'-7"

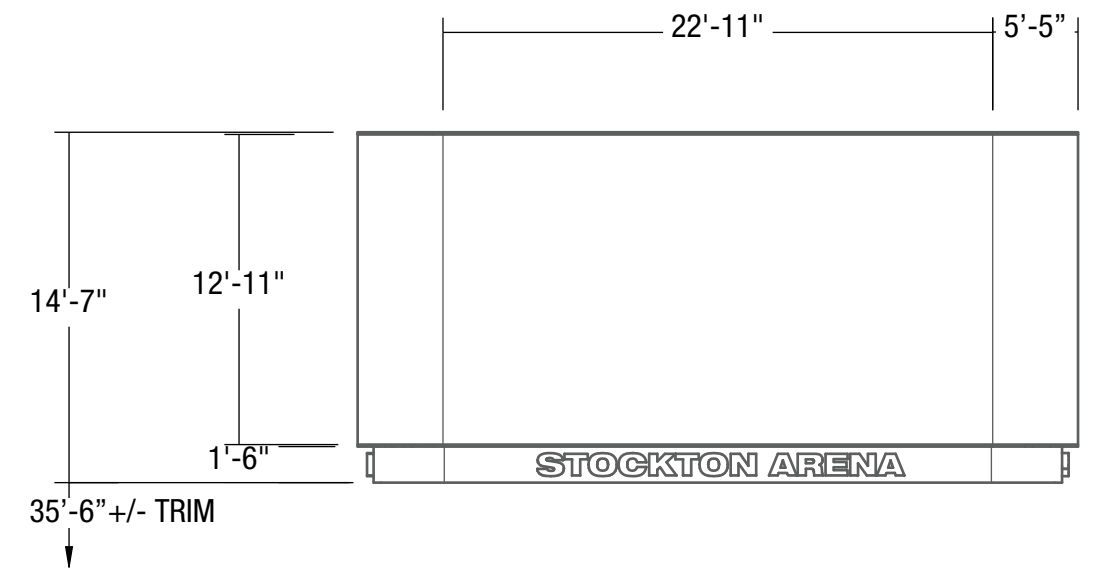

ELEVATION
1/8" = 1'-0"

CENTER HUNG LAYOUT

**ANTHONY
JAMES
PARTNERS**

3900 WESTERRE PARKWAY, SUITE 300 804.727.0070
RICHMOND, VIRGINIA 23233 www.anthonyjamespartners.com

THIS ARTWORK IS PROTECTED UNDER FEDERAL AND INTERNATIONAL COPYRIGHT LAW. EXPRESS PERMISSION FROM ANTHONY JAMES PARTNERS (AJP) IS REQUIRED FOR REPRODUCTION. RENDERINGS ARE FOR THE EXCLUSIVE USE OF DESIGNATED CLIENTS, ASSOCIATES AND AJP. THESE RENDERINGS DO NOT REPRESENT FABRICATION OR STRUCTURAL ENGINEER CERTIFIED OR STAMPED DOCUMENTS. MONITOR AND/OR PRINTER CALIBRATION MAY IMPAIR VISUAL ACCURACY OF SPECIFIED COLORS.

STOCKTON ARENA

RFP RENDERINGS

FACE ILLUMINATED
CHANNELS LETTERS
FINAL FONT TBD.

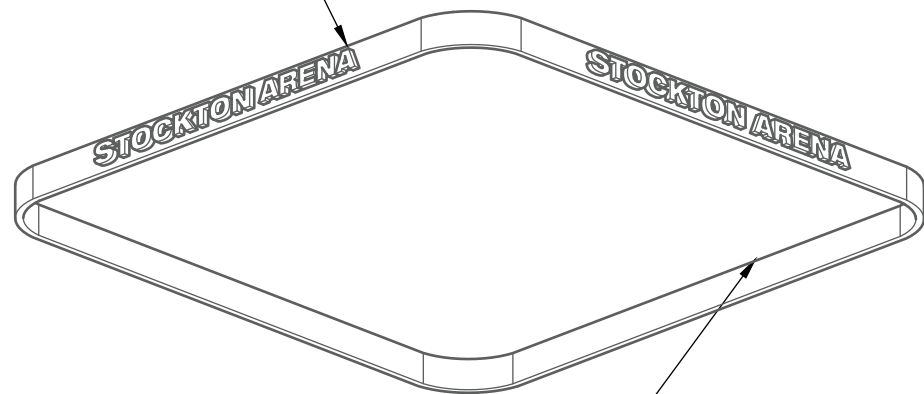

.125" ALUMINUM FABRICATED
NAMING RIGHTS RING
PAINTED PMS 877 C SATIN FINISH.

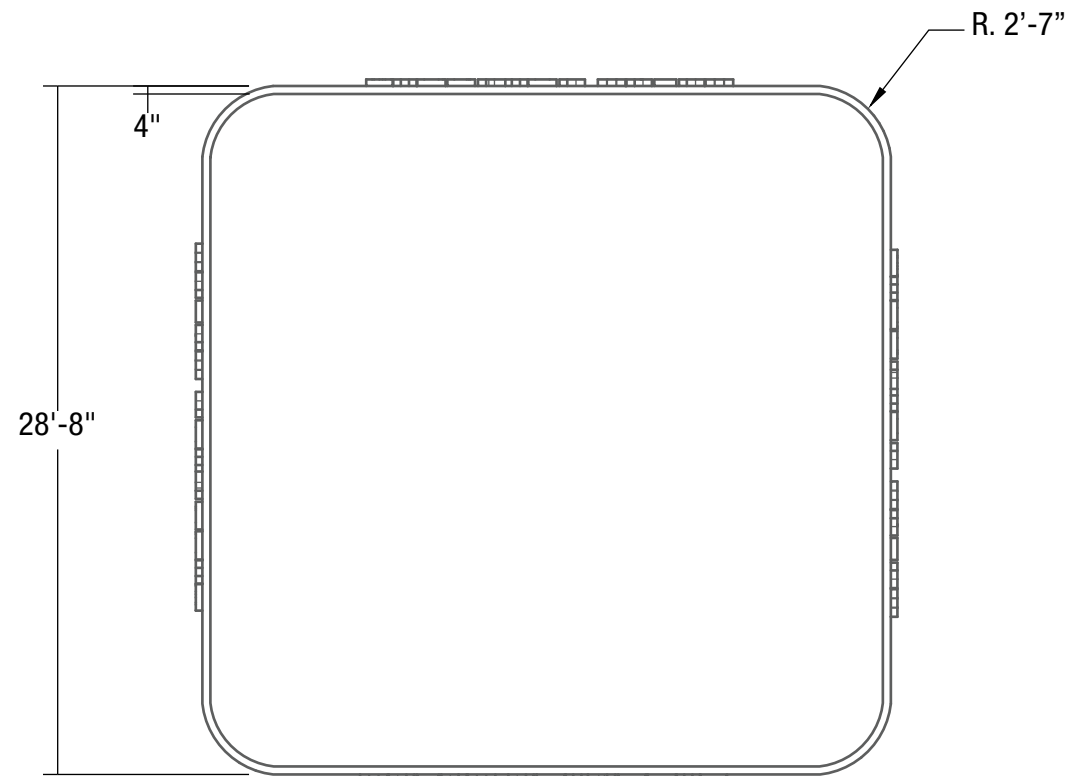

REVERSE PLAN
1/8" = 1'-0"

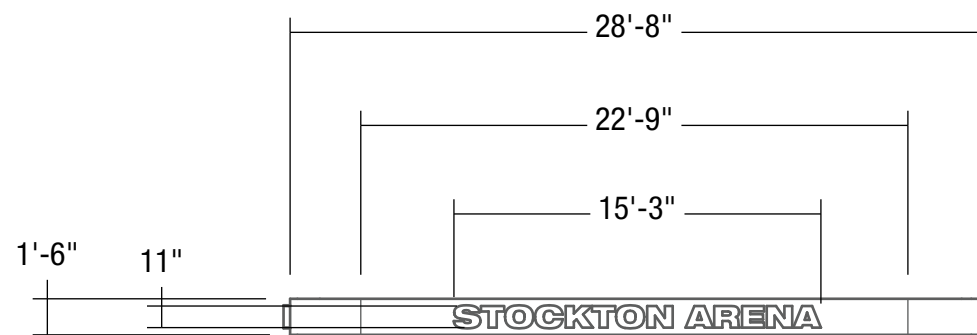

ELEVATION
1/8" = 1'-0"

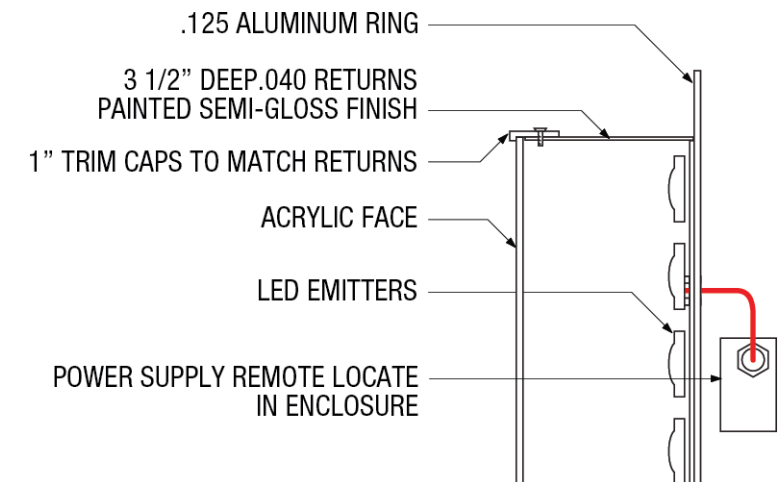

FACE ILLUMINATING SIGNAGE DETAIL
NTS

CENTER HUNG NAMING RIGHTS RING SIGNAGE

**ANTHONY
JAMES
PARTNERS**

3900 WESTERRE PARKWAY, SUITE 300 804.727.0070
RICHMOND, VIRGINIA 23233 www.anthonijamespartners.com

THIS ARTWORK IS PROTECTED UNDER FEDERAL AND INTERNATIONAL COPYRIGHT LAW. EXPRESS PERMISSION FROM ANTHONY JAMES PARTNERS (AJP) IS REQUIRED FOR REPRODUCTION. RENDERINGS ARE FOR THE EXCLUSIVE USE OF DESIGNATED CLIENTS, ASSOCIATES AND AJP. THESE RENDERINGS DO NOT REPRESENT FABRICATION OR STRUCTURAL ENGINEER CERTIFIED OR STAMPED DOCUMENTS. MONITOR AND/OR PRINTER CALIBRATION MAY IMPAIR VISUAL ACCURACY OF SPECIFIED COLORS.

STOCKTON ARENA

RFP RENDERINGS

SIGNCOMP OR SIMILAR
EXTRUDED ALUMINUM
TENSION FRAMING.

PRINTED FLEXIBLE FABRIC
REINFORCED PENETRATIONS TO
HOLD ITS SHAPE.

VERIFY EXACT PLACEMENT
AND SIZE NEEDED FOR
ACCESS.

VERIFY EXACT PLACEMENT
RIGGING POINTS TBD
1' SQUARE HOLES
6 TOTAL

EXISTING SPEAKERS/LIGHTS
AND BOTTOM PANELS TO BE
COVERED WITH UNDERBELLY
FABRIC.

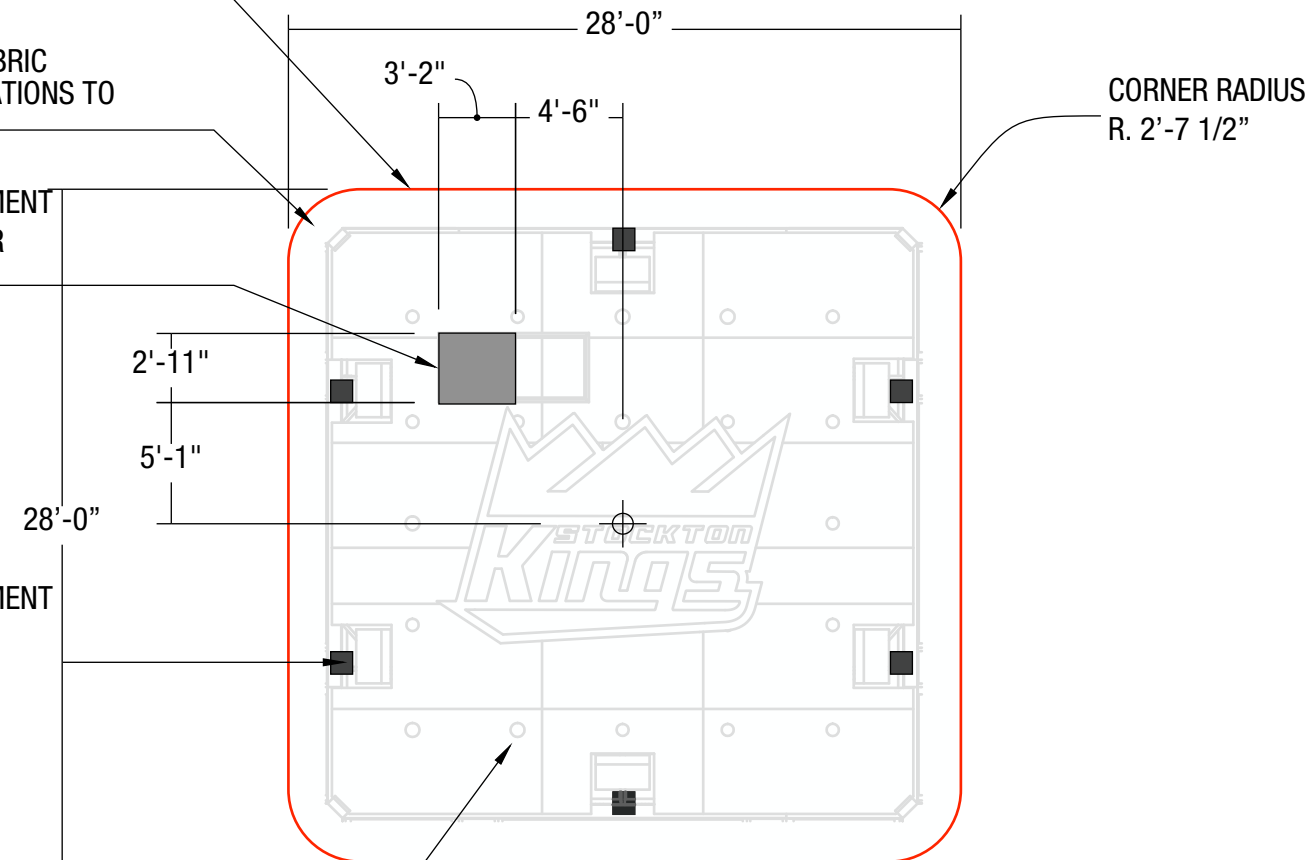

REVERSE PLAN
1/8" = 1'-0"

CORNER RADIUS
R. 2'-7 1/2"

TENSION EXTRUSION
SIGNCOMP OR SIMILAR
FRAME: #2090
PAINTED TO MATCH PMS 877C
SEMI-GLOSS FINISH.

TENSION GRAPHIC FACE

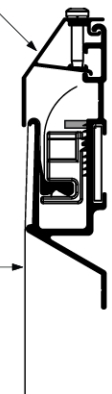

NON-ILLUMINATED TENSION DETAIL
NTS

CENTER HUNG UNDERBELLY SIGNAGE

**ANTHONY
JAMES
PARTNERS**

3900 WESTERRE PARKWAY, SUITE 300 804.727.0070
RICHMOND, VIRGINIA 23233 www.anthonyjamespartners.com

THIS ARTWORK IS PROTECTED UNDER FEDERAL AND INTERNATIONAL COPYRIGHT LAW. EXPRESS PERMISSION FROM ANTHONY JAMES PARTNERS (AJP) IS REQUIRED FOR REPRODUCTION. RENDERINGS ARE FOR THE EXCLUSIVE USE OF DESIGNATED CLIENTS, ASSOCIATES AND AJP. THESE RENDERINGS DO NOT REPRESENT FABRICATION OR STRUCTURAL ENGINEER CERTIFIED OR STAMPED DOCUMENTS. MONITOR AND/OR PRINTER CALIBRATION MAY IMPAIR VISUAL ACCURACY OF SPECIFIED COLORS.

STOCKTON ARENA

RFP RENDERINGS



FASCIA LED RIBBON (TWO TOTAL - 2.5' x 105') EXTENDS PAST CURRENT SIGNAGE BY 5' +/-

**ANTHONY
JAMES
PARTNERS**

3900 WESTERRE PARKWAY, SUITE 300 804.727.0070
RICHMOND, VIRGINIA 23233 www.anthonyjamespartners.com

THIS ARTWORK IS PROTECTED UNDER FEDERAL AND INTERNATIONAL COPYRIGHT LAW. EXPRESS PERMISSION FROM ANTHONY JAMES PARTNERS (AJP) IS REQUIRED FOR REPRODUCTION. RENDERINGS ARE FOR THE EXCLUSIVE USE OF DESIGNATED CLIENTS, ASSOCIATES AND AJP. THESE RENDERINGS DO NOT REPRESENT FABRICATION OR STRUCTURAL ENGINEER CERTIFIED OR STAMPED DOCUMENTS. MONITOR AND/OR PRINTER CALIBRATION MAY IMPAIR VISUAL ACCURACY OF SPECIFIED COLORS.

STOCKTON ARENA

RFP RENDERINGS